

# KEEPER SEALOCK



The Keeper Sealock is a C-TPAT/ISO/PAS 17712 compliant high security container/cable seal that requires two cuts for removal, doubling the security of shipments.

## Applications

- Intermodal Containers
- ISO Containers
- Trailers

## Features

- Both diameters are ISO/PAS 17712 and C-TPAT compliant.
- Total seal length of 62" (1574.8mm).
- Short exposed cable length (both diameters) is 14" (355mm).
- Length of long end cable can be increased in 2" increments.
- Cable ends lock within seal body via a patented locking device.
- Patented design secures both container hardware and keeper bars.
- Two cuts of cable, by cable cutter, required for seal removal.

## Material

- Cast zinc body
- 3/16" (5mm) 7 x 19 galvanized steel aircraft cable
- 1/8" (3mm) diameter galvanized steel cable

## Dimensions

- Standard, overall cable length is 62" (1574.8mm)
- For 1/8" version: long exposed cable length is 42-1/2" (1079mm) and seal body length is 1-3/8" (35mm)
- For 3/16" version: long exposed cable length is 42" (1067mm) and seal body is 2-1/16" (52mm)

## Strength Characteristics

### For 3/16" (5mm) diameter:

- Average pull apart force is 6,495 lbs (2,950 kg; 28.9 kN)
- Average cutting force (shear) is 2,590 lbs (1,175 kg; 11.5 kN)
- Average impact force is 50+ ft-lb (68+ Nm)
- Average bending moment is 2,000 cycles minimum

### For 1/8" (3mm) diameter:

- Average pull apart force is 3,625 lbs (1,630 kg; 16.1 kN)
- Average cutting force (shear) is 1,850 lbs (840 kg; 8.2 kN)
- Average impact force is 40-49 ft-lb (54-67 Nm)
- Average bending moment is 2,000 cycles minimum

## Decoration/Printing

- Heat or cold stamped with seven alphanumeric characters
- Characters are 1/4" (5mm) in height

## Product Numbers

- 9900058 3/16" (5mm) diameter, heat stamped  
9800058 1/8" (3mm) diameter, heat stamped

## Packaging

**3/16" Standard Packaging:** 10/Bundle - 50/Box  
**Carton Dimensions:** 15" x 11.5" x 7.25"  
(37.5cm x 29cm x 18cm)  
**Carton Weight: Gross:** 28 lbs (13 kg)

**1/8" Standard Packaging:** 10/Bundle - 100/Box  
**Carton Dimensions:** 15" x 11.5" x 7.25"  
(37.5cm x 29cm x 18cm)  
**Carton Weight: Gross:** 24.5 lbs (11 kg)

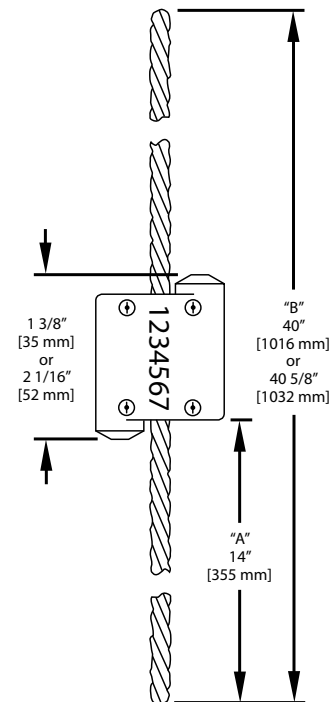

**The Only Seal That Locks.  
The Only Lock That Seals™**

**Sealock Security Systems, Inc.**

11350 NW 36th Terrace - Miami, FL 33178

Phone: (305) 418-7603

Fax: (305) 592-2970

[www.sealock.com](http://www.sealock.com)